

# IDEAS AND MOTORS

Here are some simple experiments that you can do for yourself. You perform these experiments at "YOUR OWN RISK".....

## N POLE MOTOR

THIS MOTOR IS NOT A SELF START TYPE, YOU MUST START IT.

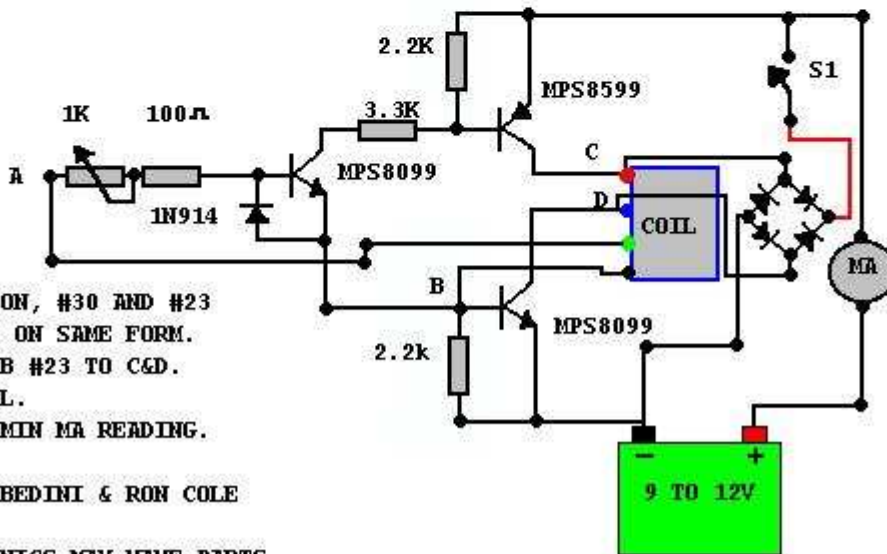
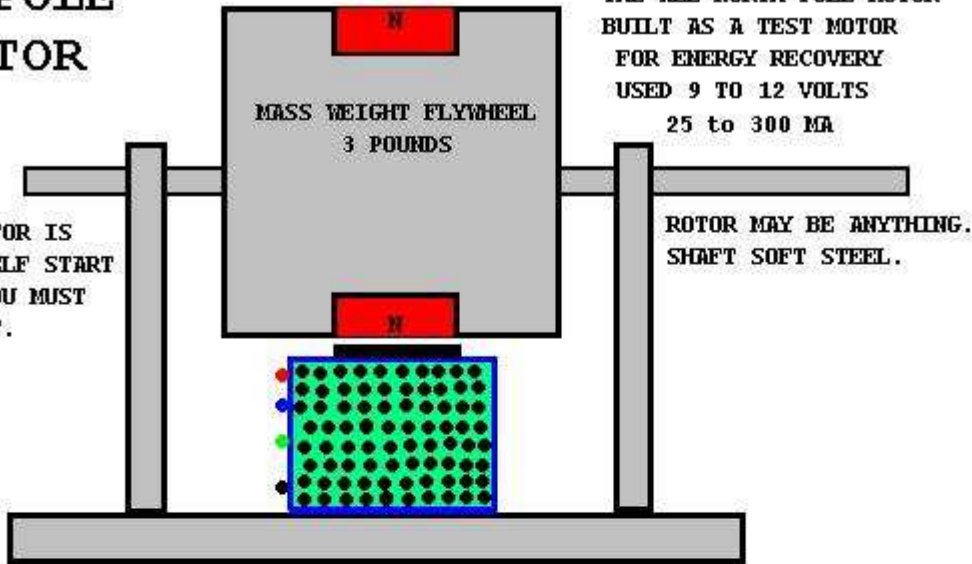

COIL INFORMATION, #30 AND #23 BI-FILER WOUND ON SAME FORM. #30 WIRE TO A&B #23 TO C&D. 850 TURNS TOTAL. ADJUST 1K FOR MIN MA READING.

BUILT BY JOHN BEDINI & RON COLE  
 9-19-1984.  
 BEDINI ELECTRONICS MAY HAVE PARTS FOR SALE TO BUILD THIS MOTOR. 1-208-667-8300

**ADAMS TYPE TEST MOTOR  
FOR ENERGY RECOVERY  
WARNING HIGH SPEED ROTOR  
3000 RPM BUILD AT YOUR OWN  
RISK**

ALL NORTH POLE ROTOR

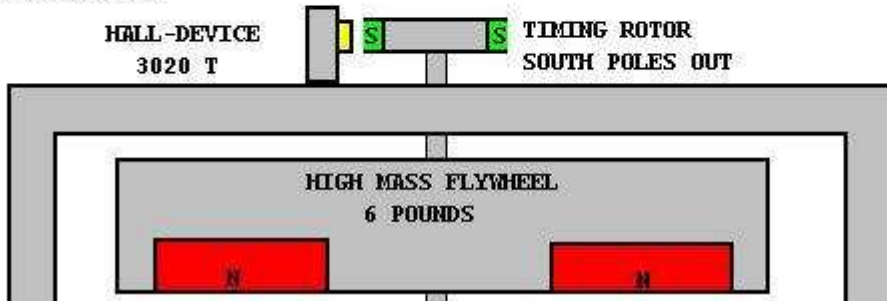

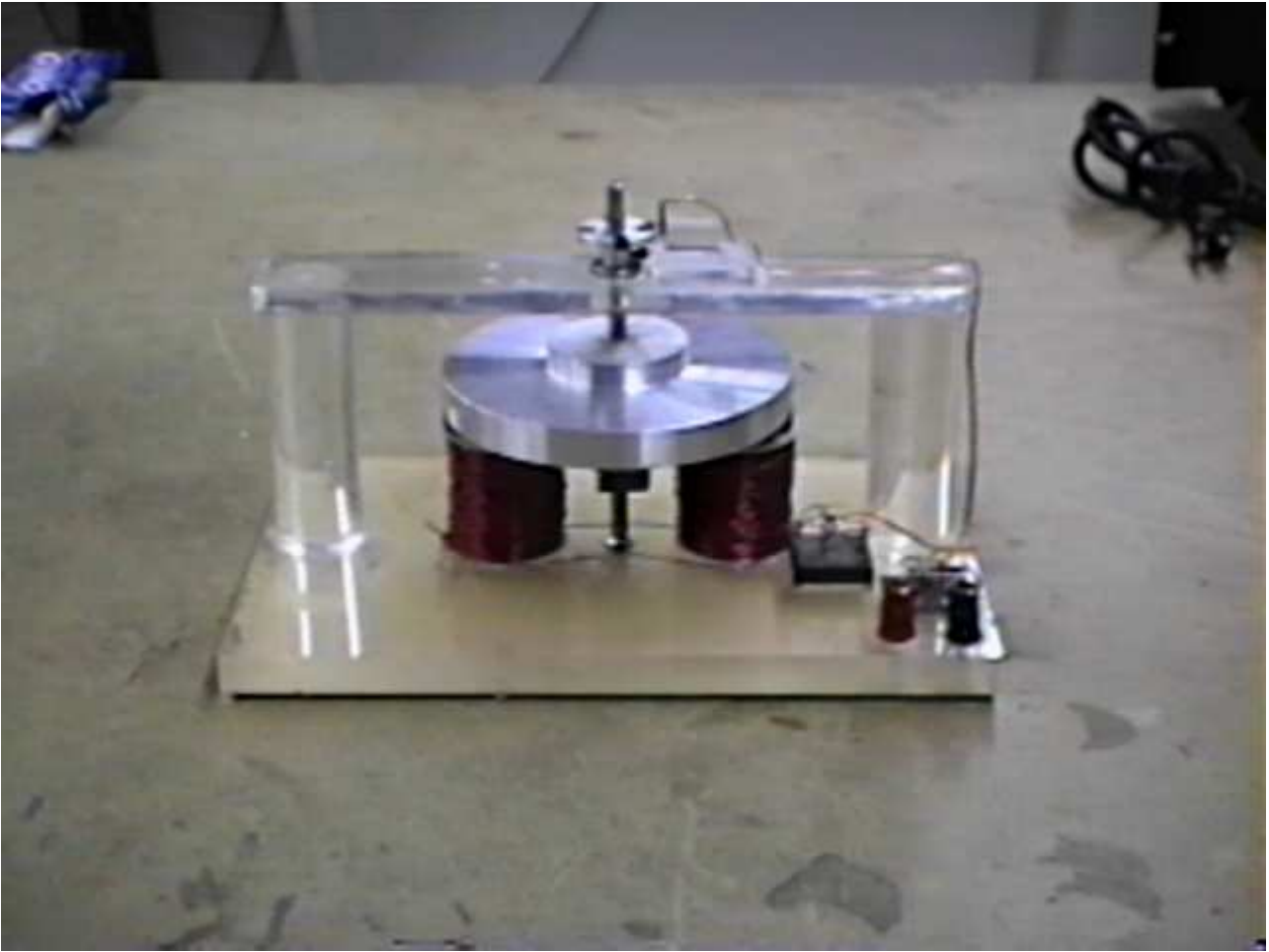

Prototype Adams Motor

### BUCKING FIELD ENERGIZER

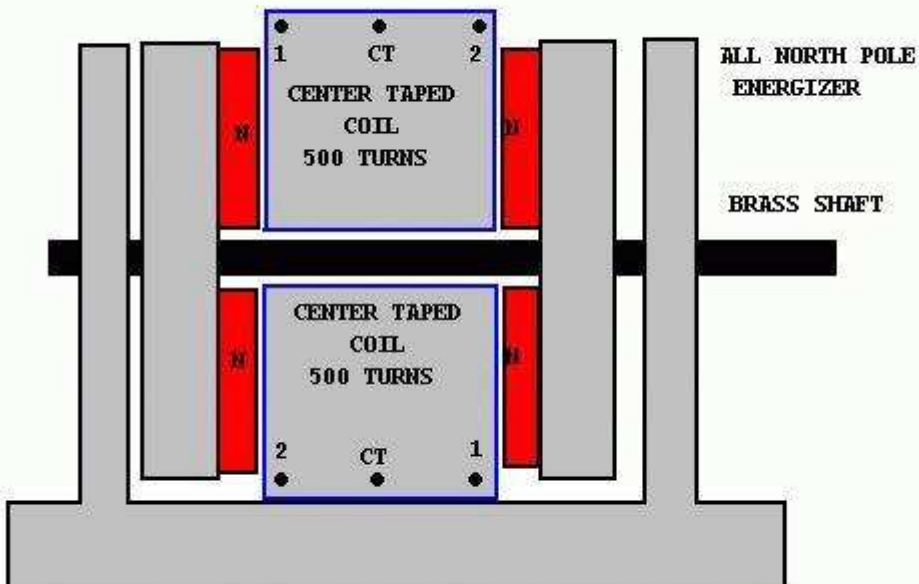

BUCKING ENERGIZER BUILT BY JOHN BEDINI AND RON COLE  
IN 1988 TO TEST FOR UNKOYV WAVES IN A SCALAR FIELD.

## FLUX GATE TRANSFORMER

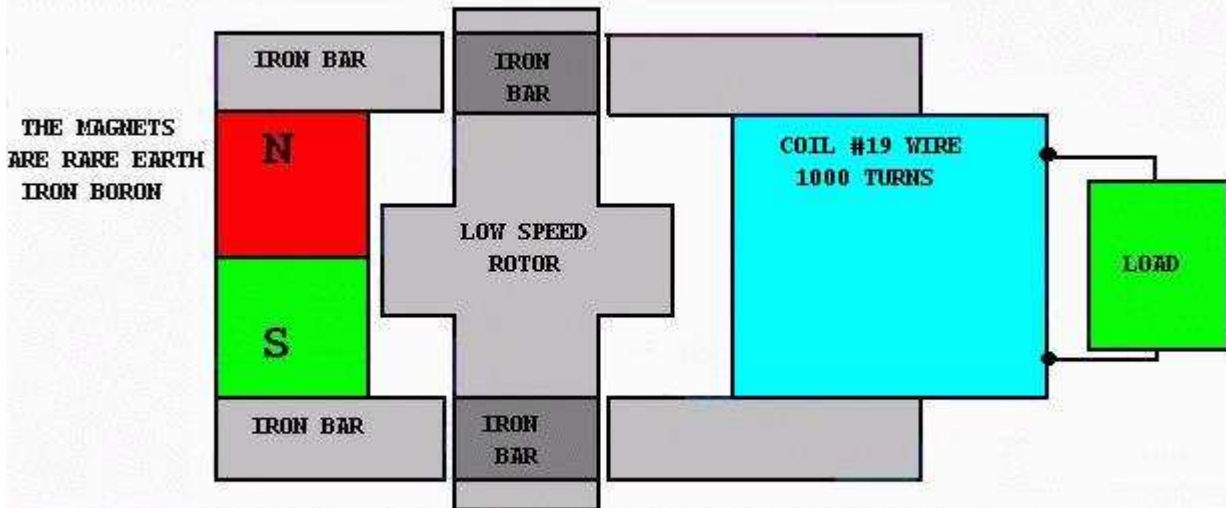

FLUX GATE TRANSFORMER. THIS GATES THE MAGNETIC FLUX BY TURNING THE ROTOR BUILT BY JOHN BEDINI AND RON COLE JULY 1988. UNDER LOAD THEIR IS NO BACK EMF FORCE ON MOTOR.

## MAGNETIC FLUX GATE

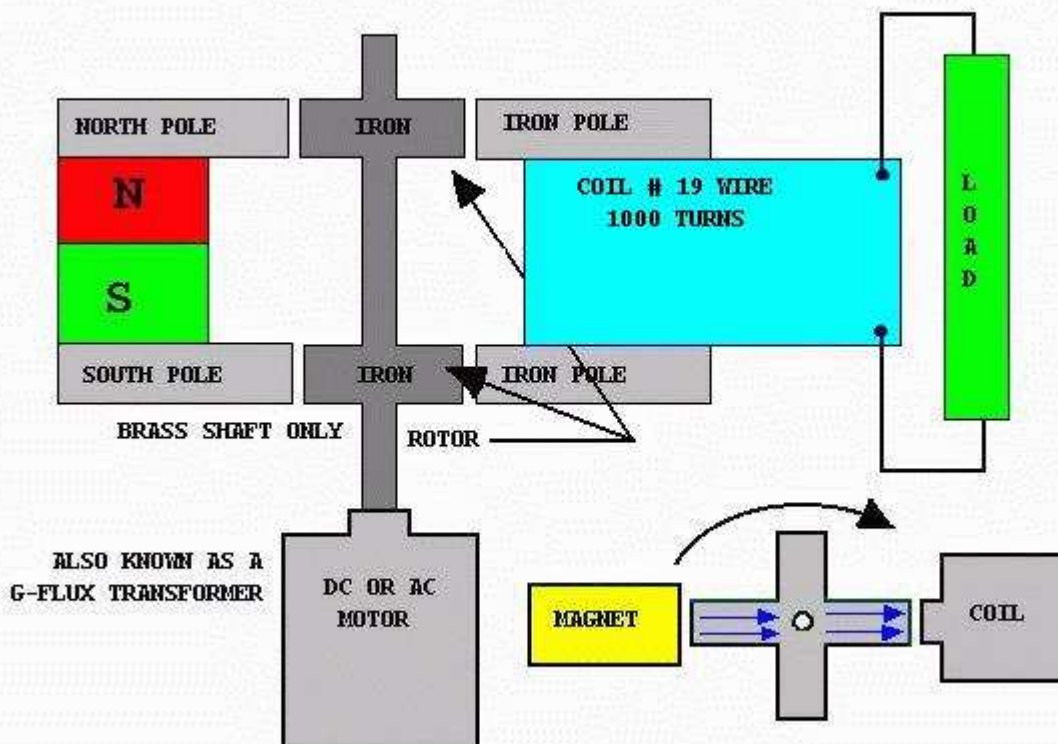

ALSO KNOWN AS A G-FLUX TRANSFORMER

THIS IS HOW TO GATE THE MAGNETIC FLUX

## MAGNETIC NOTCH (GATE)

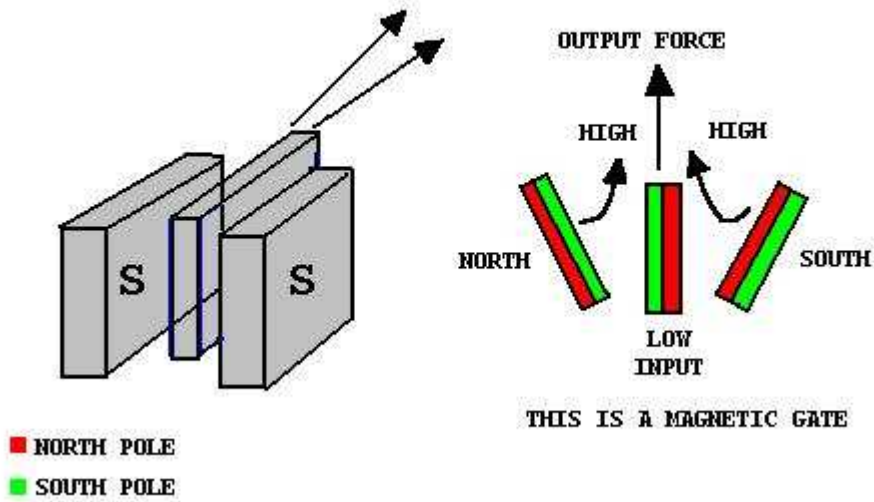

## MAGNETIC NOTCH MOTOR (GATING FLUX)

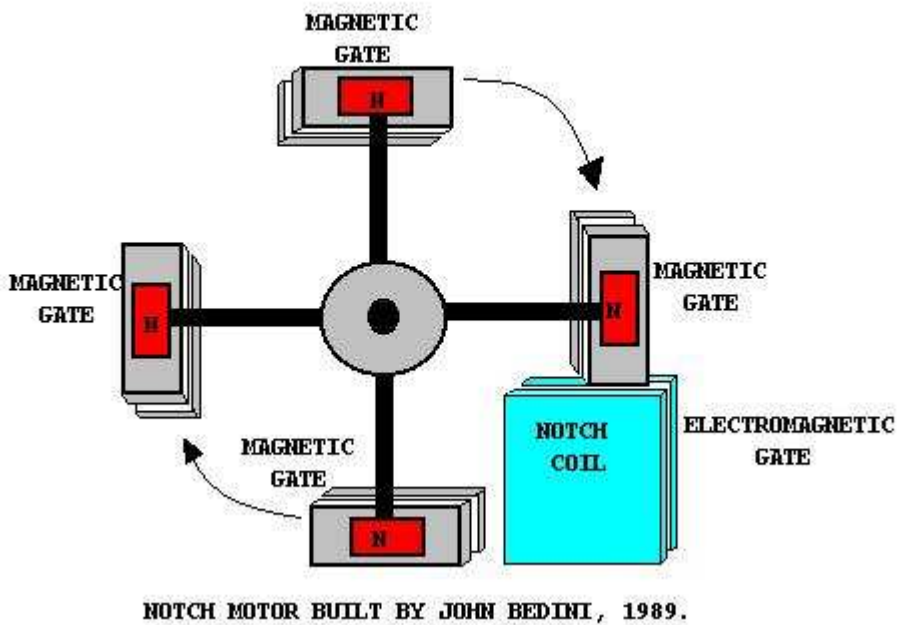

## G-FLUX GATING MOTOR 3000 RPM

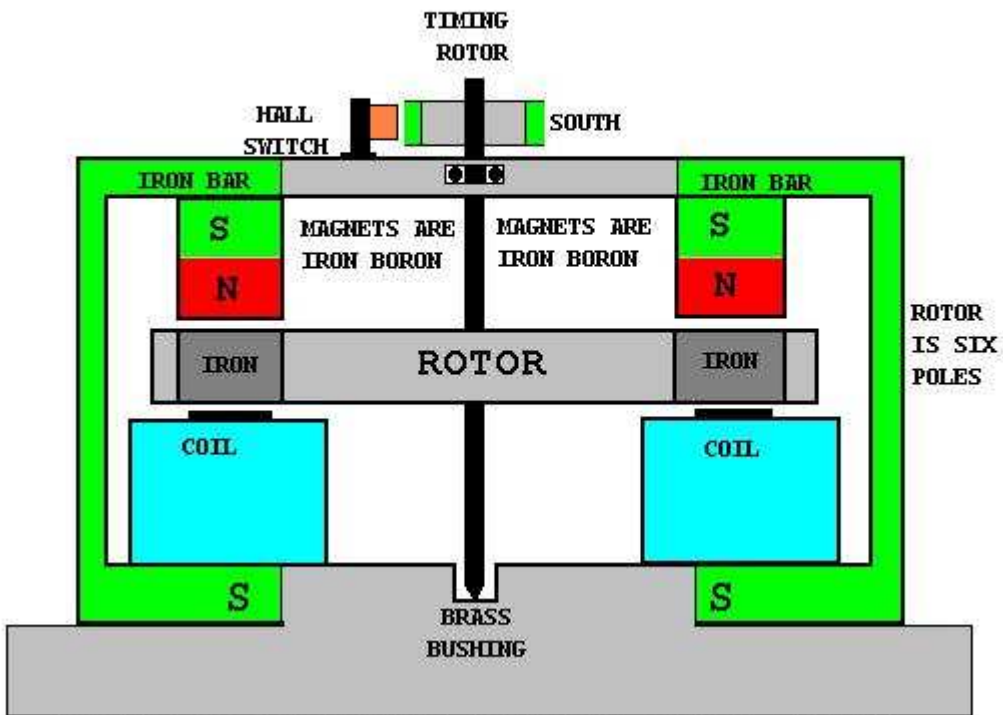

G-FLUX GATING MOTOR BUILT BY JOHN BEDINI, RON COLE JULY 1989

## G-FLUX MOTOR ENERGIZER

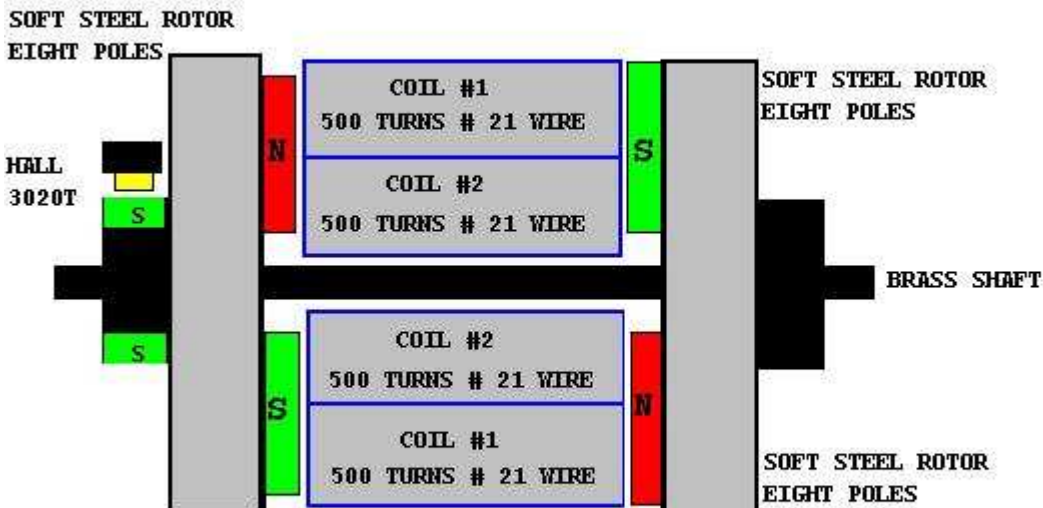

G-FLUX MOTOR ENERGIZER BUILT BY JOHN BEDINI, AND RON COLE  
AUG 23 1986.

BIFILER WOUND COILS # 21 WIRE MAGNETS IRON BORON

SOFT STEEL ROTOR  
EIGHT POLES

## MOTOR G-FIELD ENERGIZER TWO BATTERY SYSTEM

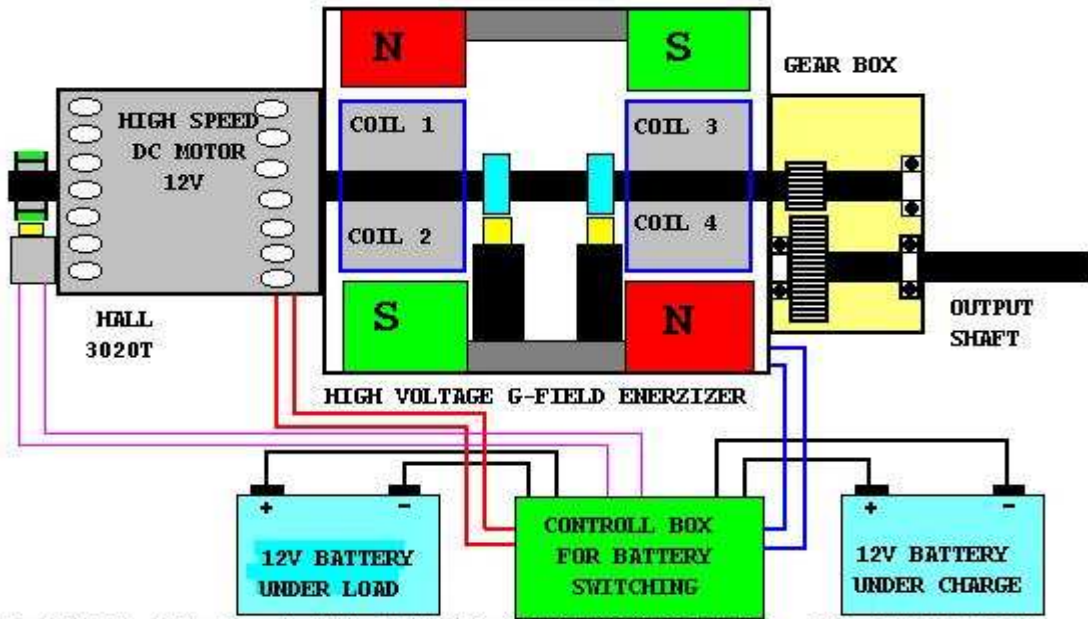

THIS MOTOR G-FIELD ENERGIZER WAS BUILT BY JOHN BEDINI AND ROBERT LEE MOTORS IN 1988. THE CONTROLLER SWITCHES THE BATTERIES, WHEN THE BATTERY UNDER LOAD DISCHARGES TO 11.1 VOLTS. THE CONTROLLER THEN SWITCHES THE CHARGED BATTERY TO DRIVE THE MOTOR AND THE ENERGIZER CHARGES THE LOW BATTERY .....

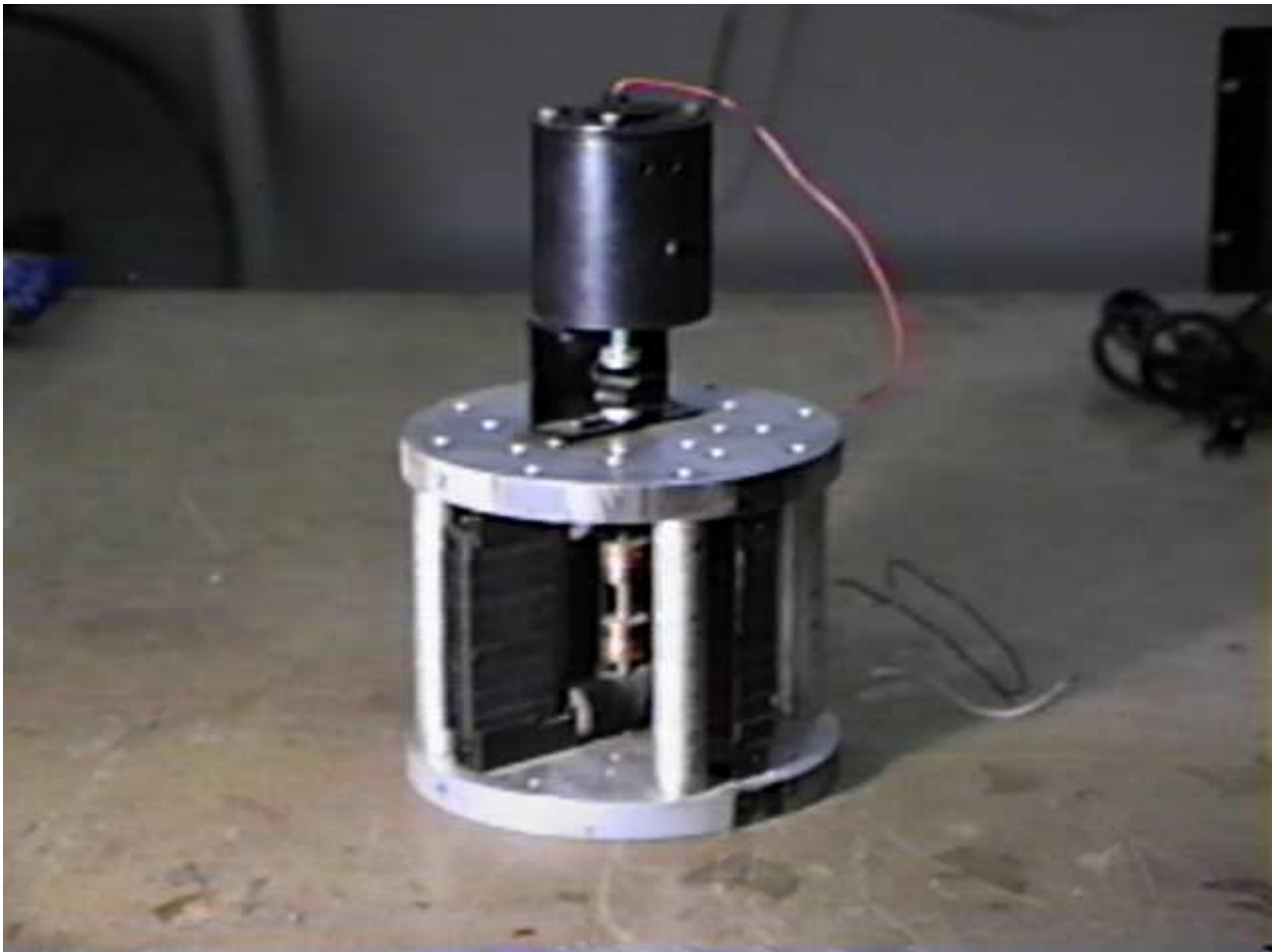

Prototype G-Field Generator

# DC MOTOR G-FLUX ENERGIZER TWO BATTERY SYSTEM

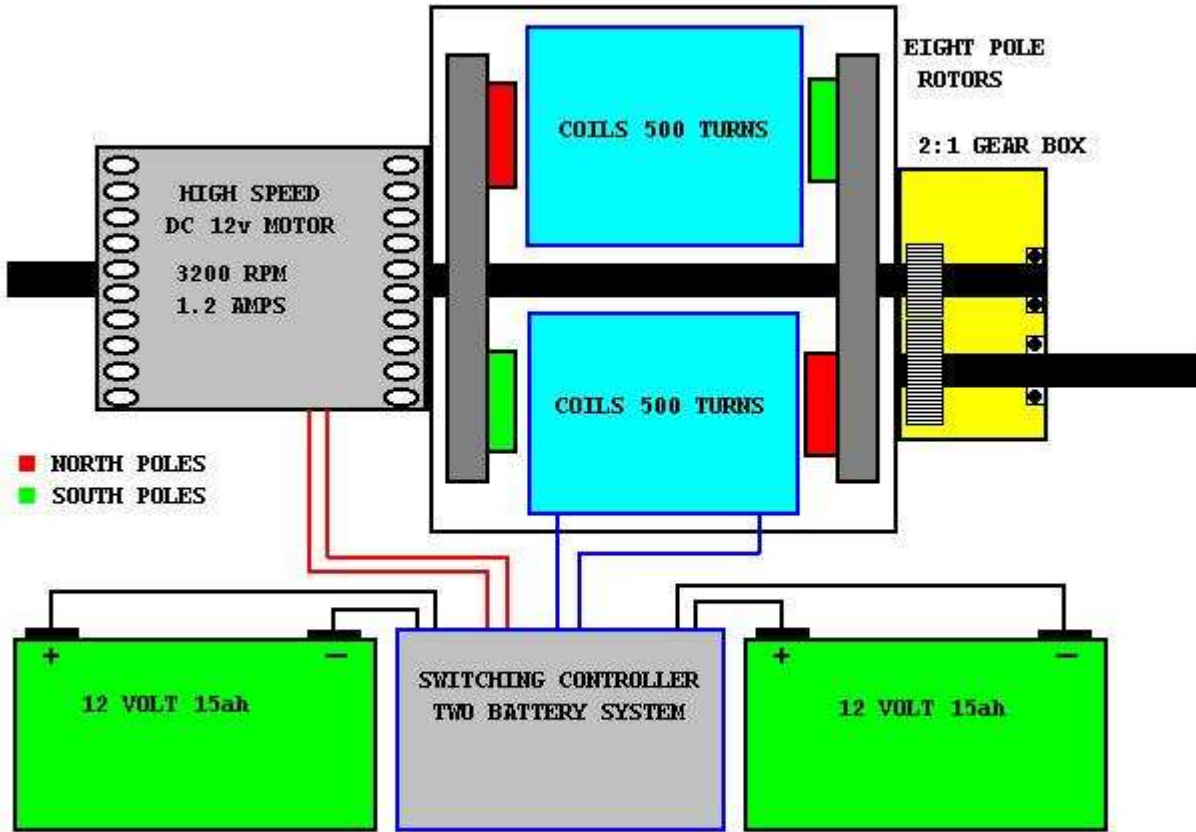

DC MOTOR G-FIELD ENERGIZER BUILT BY JOHN BEDINI AND ROBERT LEE MOTORS JULY 1989. THIS POWERED A 10 FOOT BOAT, THIS WAS THE LAST UNIT TO BE BUILT BY ROBERT LEE MOTORS. THE CIRCUIT WORKS THE SAME AS THE TOP PICTURE ONLY THE BATTERIES ARE LARGER.

Copyright © 1996 John Bedini

